

Step 1: Setting out and tingle fitting

1. Unpack your flashing kit by gently unrolling on a flat, clean surface - taking care not to cut or scratch the lead.
2. The slates/tiles should be fitted up to the timber fillet, with the coursing calculated to suit the front flashing part of the kit. Fix the lead tingles, at regular intervals no more than 450mm apart. Use two copper nails as close to the top of the tile/slate as possible. (See figure A).
3. Place rooflight frame in the opening and temporarily fix the upper part in the desired location.
4. Slide the front lead flashing under the frame as high as possible. It is essential that the main part of the frame achieves the necessary overlap.
5. Fold the lead tingles up to hold the flashing piece in position. Trim these off so that a 50mm square is still visible and lightly dress down flat.
6. Remove the rooflight frame.

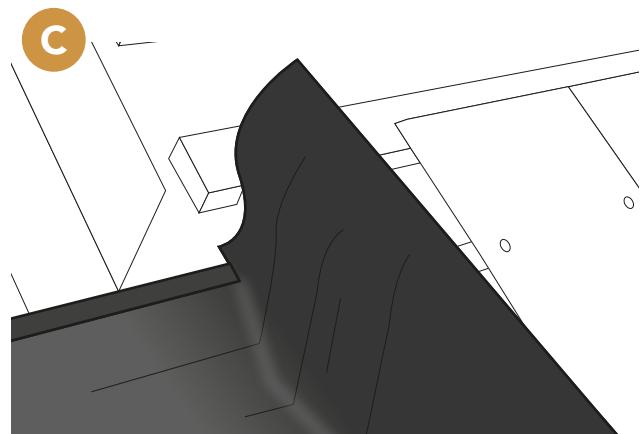
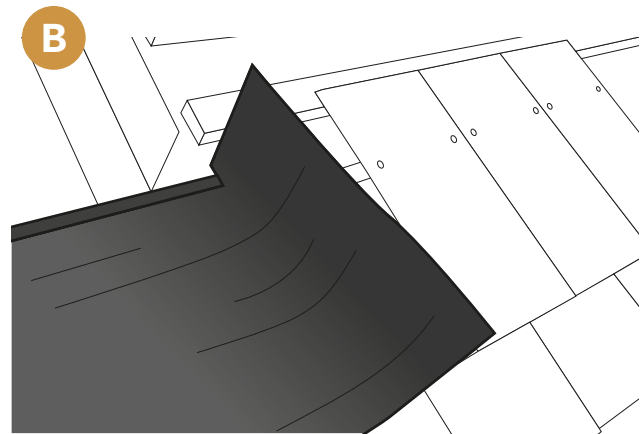
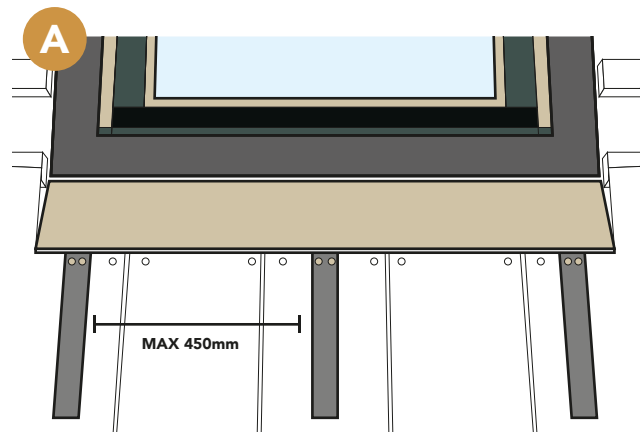

Step 2: Dressing the front flashing

1. Using copper nails – fix the front flashing in place by nailing through the welted top edge and 150mm intervals. Only fix the central third of each section to allow for thermal movement.
2. Lift the two 150mm 'ears' on the outer edge of the flashing up vertical angle. (See figure B)
3. Using a rounded lead dresser, gently set the lead into the shape of your wooden fillet. This is essential for the roof-light frame to sit properly in position. (See figure C)
4. Then begin to flatten down the vertical ear by dressing the lead around in an 'outward and upward' motion. (See figure D). Take care not to repeatedly hit the same area to avoid overly thinning the lead.
5. Place rooflight frame back in position, ensuring the frame down far enough to touch the lead.
6. Fully fix the frame in position.
7. Your front flashing should now look like figure E.

Once the front flashing is held securely in place by the tingles, the copper clips should be installed.

1. Open the pack of clips. This should be install at even intervals, the same as the tingles.
2. Engage clip under the welted lip of the front flashing.
3. While pulling it firmly into the welt, bend the clip down into the roof opening.
4. Using stainless steel screws, gently tighten the screw (See figure F). Be sure not to shear the screw off.

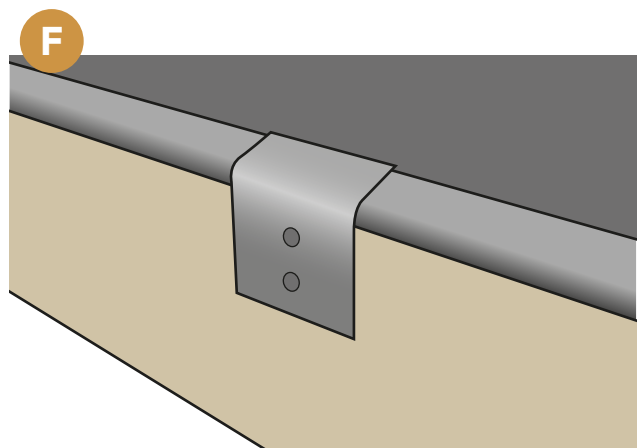
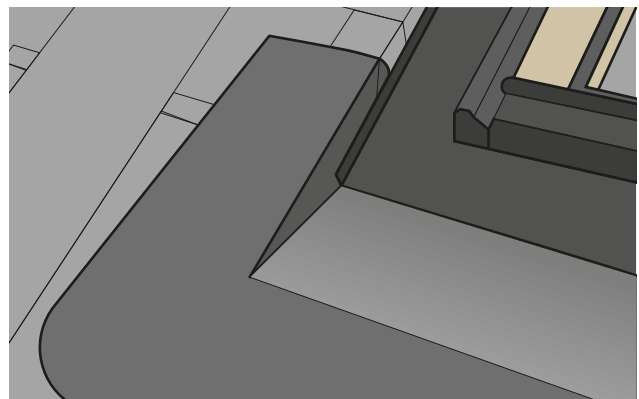
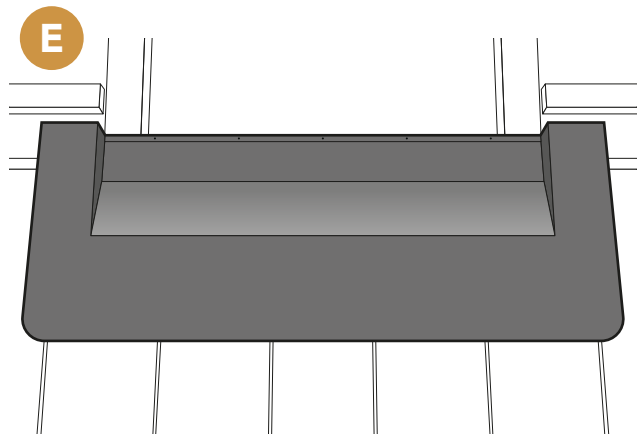
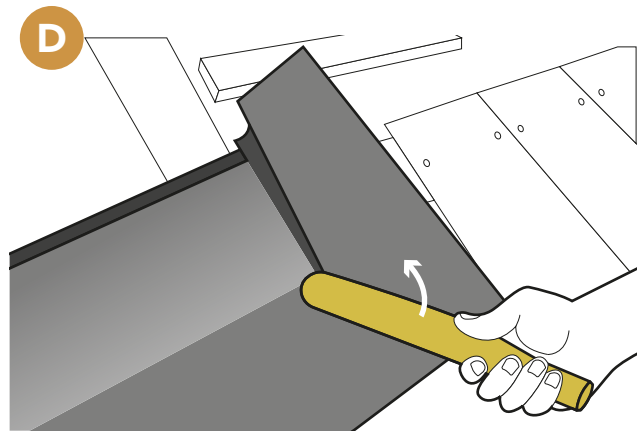

Step 3: Soakers

1. Unpack the soakers, and find the set labeled 'First soaker right'.
2. This is the first soaker to be fitted to the right hand side as you face the rooflight on the roof. The soakers sit on each slate or tile, with the 25-45mm edge pointing down towards the frame. This is to cap off the slate/tile to prevent leaves and debris entering under the slate/tile. The first soaker is trimmed to roughly fit against the front flashing. Additional trimming may be needed.
3. Continue to fit all the slates/tiles on both sides of the rooflight. Allow a 25mm gap up the side of the opening part of the window. Using a piece of 25x50mm roof batten works well.

Step 4: Top flashing

1. Place the top flashing in position so that the bottom edge lines up with the correct slate/tile gauge. (See figure G)
2. Carefully cut the lead to suit the desired position (See figure H). This should allow for the lead to be dressed into the shape shown in figure I.
3. Like the front flashing, fix the lead with copper nails at the top of the top flashing at 150mm intervals.
4. You may want to fit the opening part of the window while it is still accessible from above the top flashing.
5. Continue slating/tiling.

