

GENERAL INFORMATION
 3RD ANGLE PROJECTION
 DO NOT SCALE - IF IN DOUBT, ASK
 REMOVE ALL SHARP EDGES AND BURRS

Metal & Glass Ltd shall bear no liability for failure to comply with the applicable laws, building codes and safety requirements by the user of the product, architect, installer or owner of the building

TOLERANCES UNLESS OTHERWISE SPECIFIED	
LINEAR - 0 DECIMAL PLACES	±1.0mm
LINEAR - 1 DECIMAL PLACES	±0.50mm
LINEAR - 2 DECIMAL PLACES	±0.15mm
ANGULAR	
	±1.0°
SURFACE FINISH - GENERAL	
SURFACE FINISH - MACHINED	
SURFACE FINISH - GROUND	
SURFACE FINISH - POLISHED	
SCREW THREAD - INTERNAL	6H
SCREW THREAD - EXTERNAL	6g

ITEM NO.	PART NUMBER	DESCRIPTION	QTY.
1	MGL1020A	BESPOKE FIXED CONSERVATION ROOFLIGHT GA	1

NOTES:
 INSTALLER TO PROVIDE ADEQUATE FITTING ALLOWANCE TO ALL SIDES OF ROOF FRAMING TO ENSURE EASE OF INSTALLATION.
 DESIGN & CONSTRUCTION OF ROOF FRAMING TO BE APPROVED BY CLIENTS STRUCTURAL ENGINEER
 ROOFLIGHT TO BE SUPPLIED FULLY GLAZED

THIS IS A PERMANENTLY FIXED (NON-OPENING) ROOFLIGHT ENVIRONMENT CATEGORY - C5

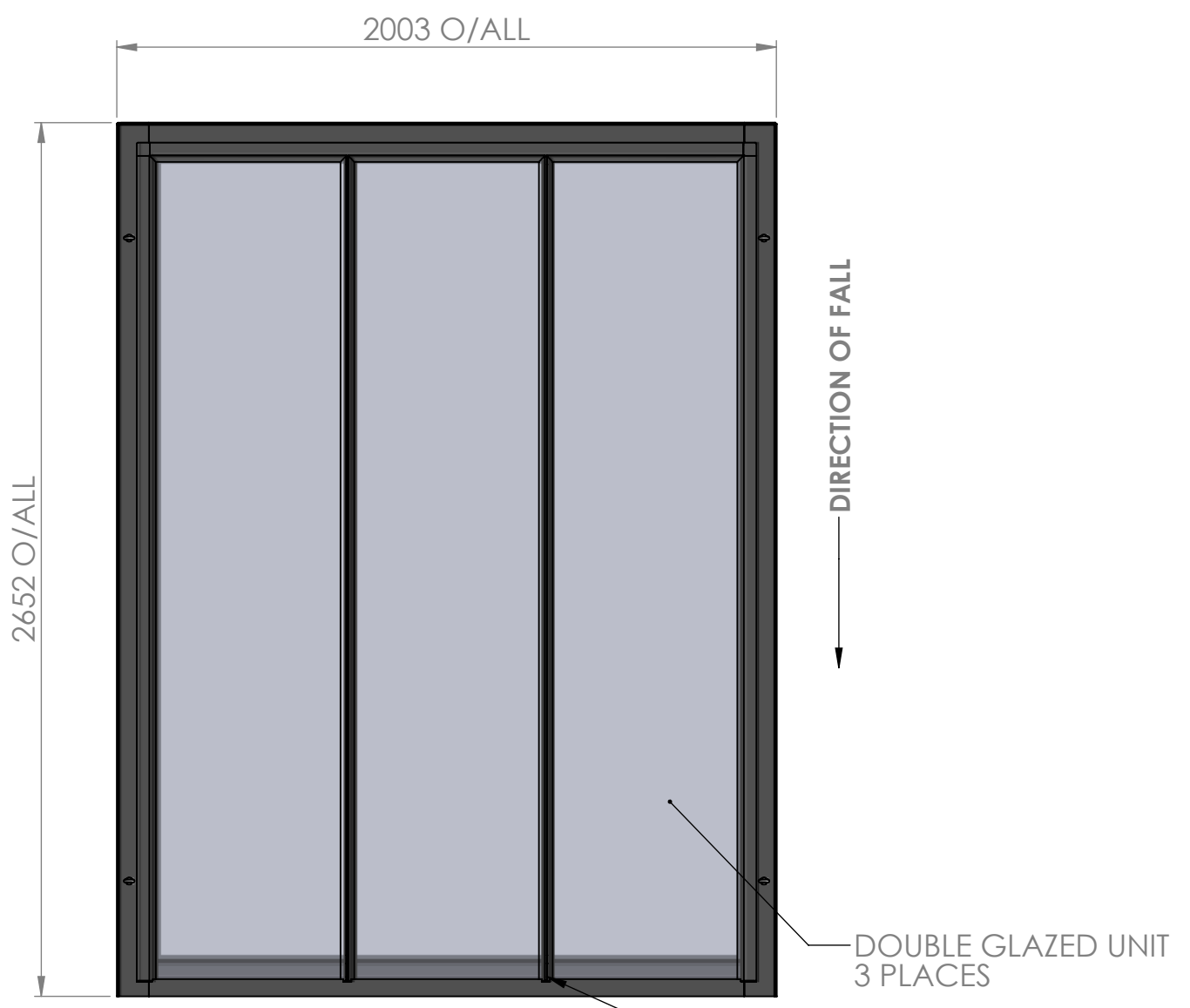

VIEW FROM OUTSIDE

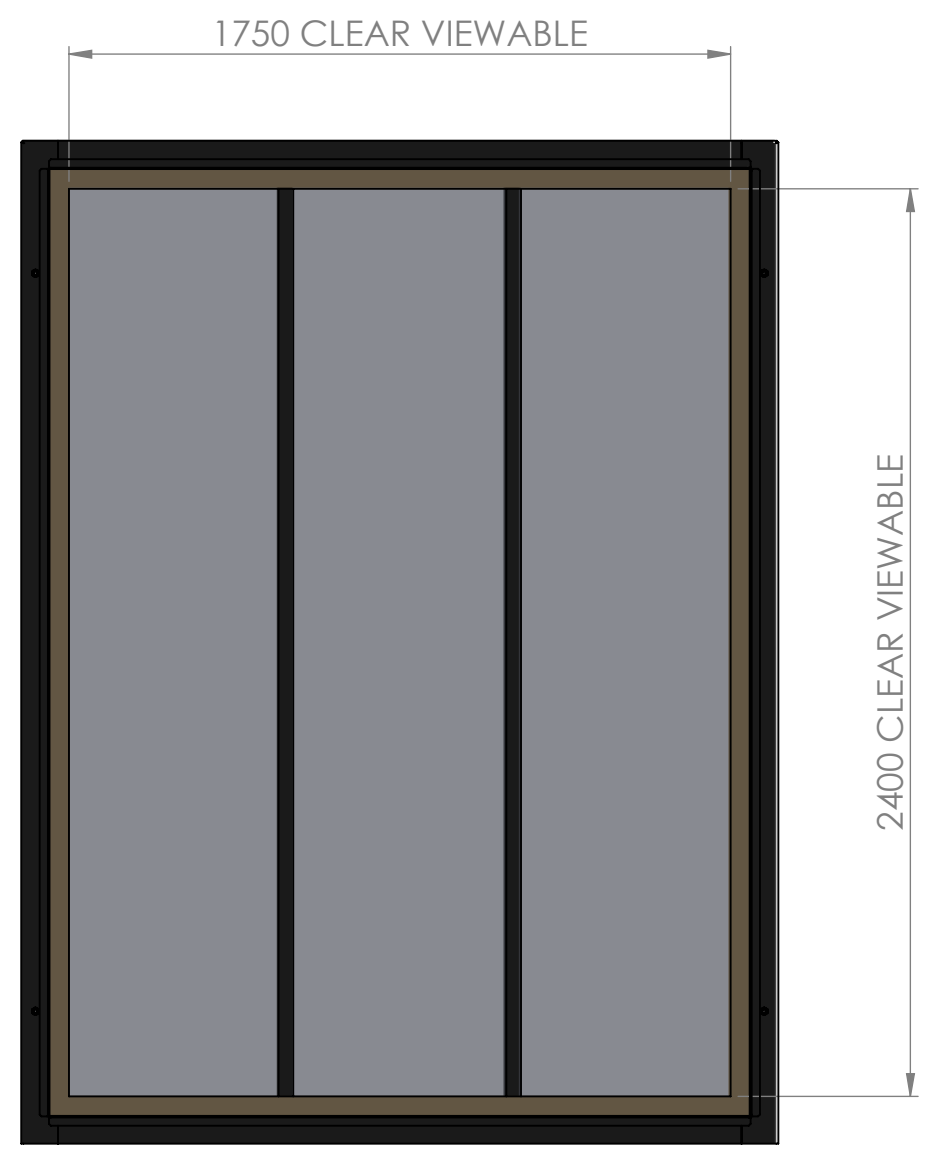

VIEW FROM INSIDE BUILDING

DOUBLE GLAZED UNIT
3 PLACES
 GLAZING BAR
2 PLACES

GLAZING SPECIFICATION:
 (TO BE APPROVED BY CLIENTS STRUCTURAL ENGINEER)
 6mm TOUGHENED BIO CLEAN NATURA SELF-CLEAN/SOLAR CONTROL
 16mm BLACK WARM EDGE SPACER (ARGON GAS)
 6mm TOUGHENED PLANITHERM ONE LOW E



THE INFORMATION CONTAINED IN THIS DRAWING IS THE SOLE PROPERTY OF METAL & GLASS LTD. ANY REPRODUCTION IN PART OR AS A WHOLE WITHOUT WRITTEN PERMISSION IS STRICTLY PROHIBITED
 SHEET: 1 OF 3 - A3
 DATE: 07/05/21 UNITS: mm; kg

DRAWN: S.C
 SCALE: 1:20
 WEIGHT: 226

TITLE: BESPOKE FIXED CONSERVATION ROOFLIGHT GA
 REF: STELLA BESPOKE CONSERVATION ROOFLIGHT

MATERIAL: 316 ST STEEL
 SEALS/SEALANT COLOUR: BLACK/BLACK
 FINISH: SWEEP BLAST & POWDER COAT PZ790 SYSTEM RAL7001 SILVER MATT FINISH

PART TYPE: MANUFACTURED
 PART REF:
 DRG. No.

1 2 3 4 5 6 7 8 9 10 11 12

GENERAL INFORMATION
 3RD ANGLE PROJECTION
 DO NOT SCALE - IF IN DOUBT, ASK
 REMOVE ALL SHARP EDGES AND BURRS

Metal & Glass Ltd shall bear no liability for failure to comply with the applicable laws, building codes and safety requirements by the user of the product, architect, installer or owner of the building

TOLERANCES UNLESS OTHERWISE SPECIFIED	
LINEAR - 0 DECIMAL PLACES	±1.0mm
LINEAR - 1 DECIMAL PLACES	±0.50mm
LINEAR - 2 DECIMAL PLACES	±0.15mm
ANGULAR	
	±1.0°
SURFACE FINISH - GENERAL	
	3.2 µm
SURFACE FINISH - MACHINED	
	1.6 µm
SURFACE FINISH - GROUND	
	0.4 µm
SURFACE FINISH - POLISHED	
	0.2 µm
SCREW THREAD - INTERNAL	
	6H
SCREW THREAD - EXTERNAL	
	6g

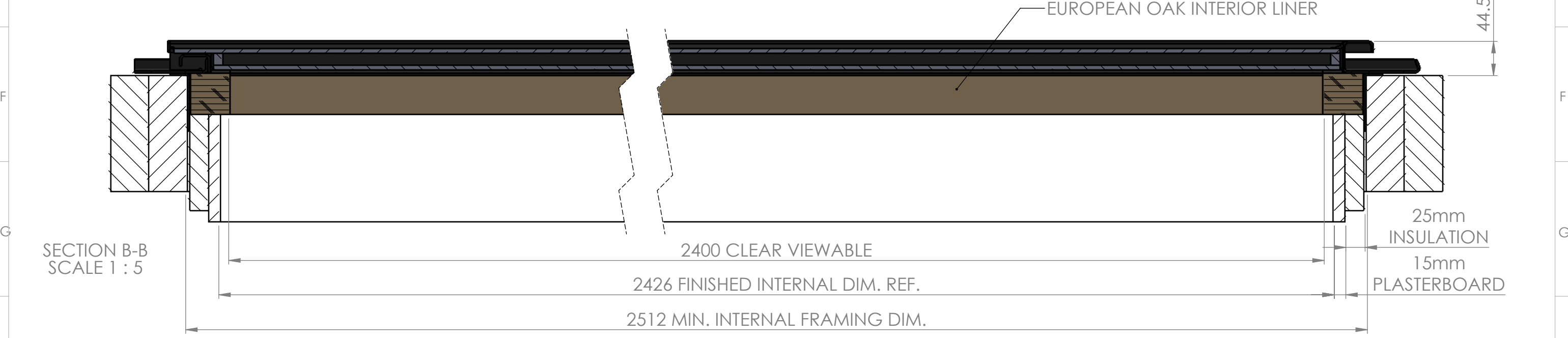
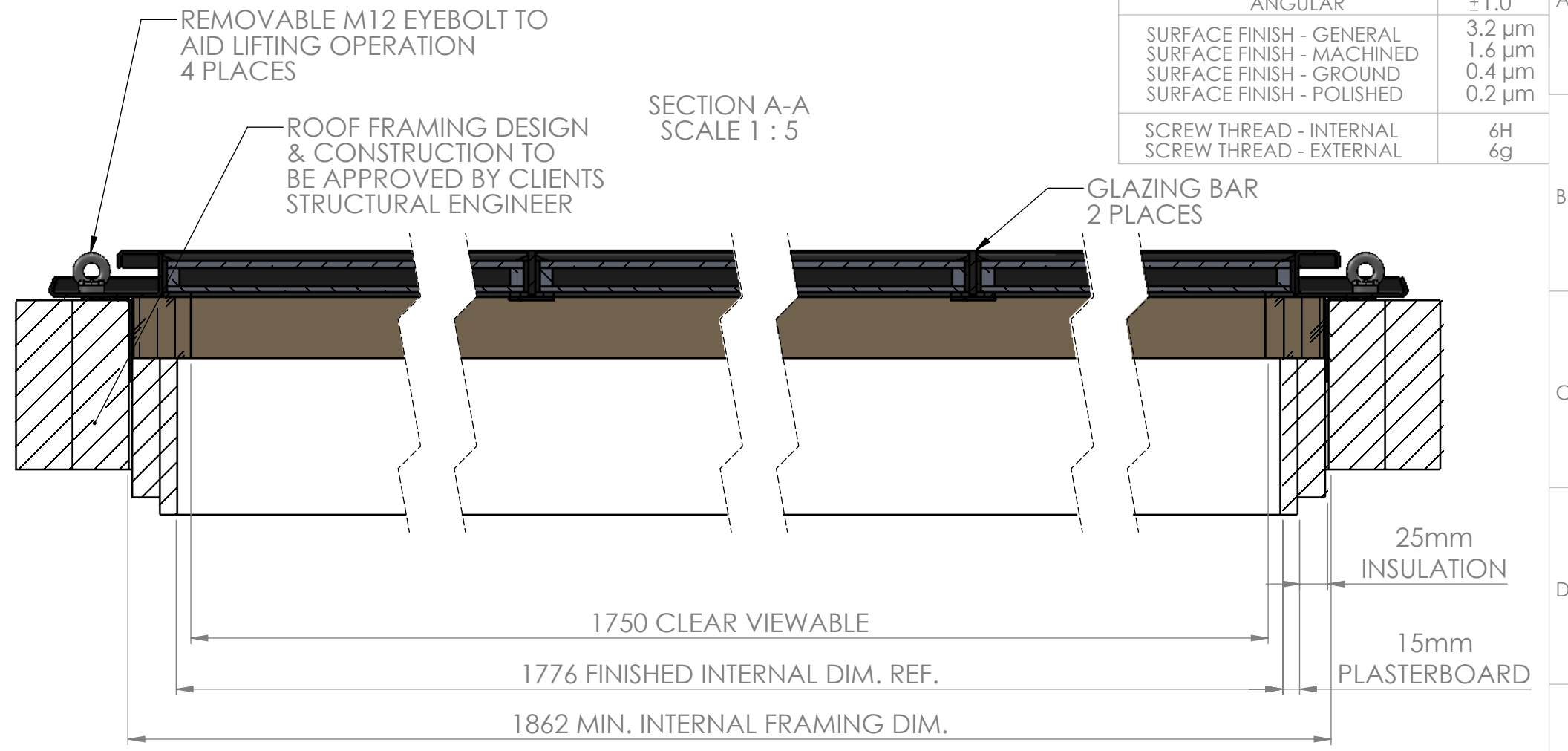
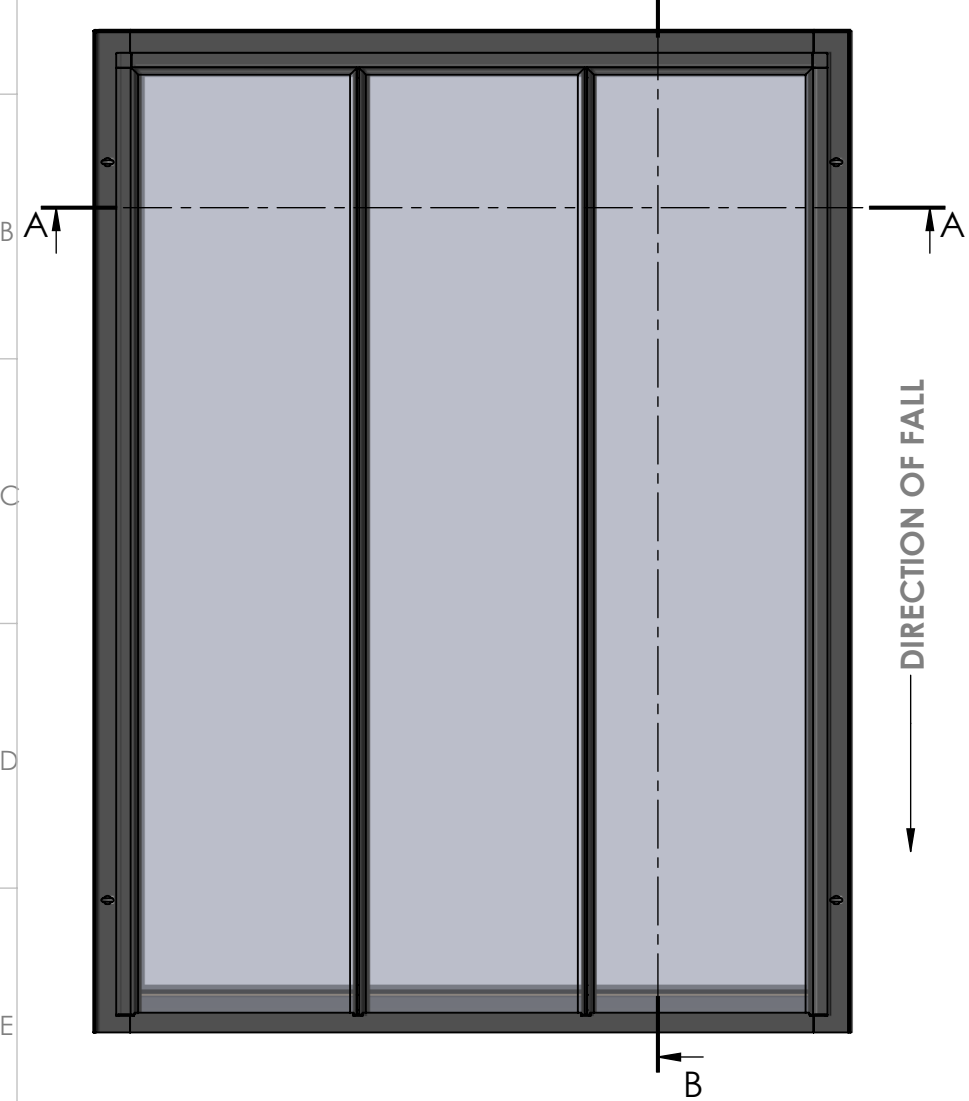

	THE INFORMATION CONTAINED IN THIS DRAWING IS THE SOLE PROPERTY OF METAL & GLASS LTD. ANY REPRODUCTION IN PART OR AS A WHOLE WITHOUT WRITTEN PERMISSION IS STRICTLY PROHIBITED.	DRAWN: S.C SCALE: 1:20 WEIGHT: 226	TITLE: BESPOKE FIXED CONSERVATION ROOFLIGHT GA	MATERIAL: 316 ST STEEL SEALS/SEALANT COLOUR: BLACK/BLACK	PART TYPE: MANUFACTURED PART REF:
	SHEET: 2 OF 3 - A3	REF: STELLA BESPOKE CONSERVATION ROOFLIGHT	FINISH: SWEEP BLAST & POWDER COAT PZ790 SYSTEM RAL7001 SILVER MATT FINISH	DRG. No.	
	DATE: 07/05/21 UNITS: mm; kg				

1 2 3 4 5 6 7 8 9 10 11 12

GENERAL INFORMATION
 3RD ANGLE PROJECTION
 DO NOT SCALE - IF IN DOUBT, ASK
 REMOVE ALL SHARP EDGES AND BURRS

Metal & Glass Ltd shall bear no liability for failure to comply with the applicable laws, building codes and safety requirements by the user of the product, architect, installer or owner of the building

TOLERANCES UNLESS OTHERWISE SPECIFIED	
LINEAR - 0 DECIMAL PLACES	±1.0mm
LINEAR - 1 DECIMAL PLACES	±0.50mm
LINEAR - 2 DECIMAL PLACES	±0.15mm
ANGULAR	
	±1.0°
SURFACE FINISH - GENERAL	
SURFACE FINISH - MACHINED	
SURFACE FINISH - GROUND	
SURFACE FINISH - POLISHED	
SCREW THREAD - INTERNAL	6H
SCREW THREAD - EXTERNAL	6g

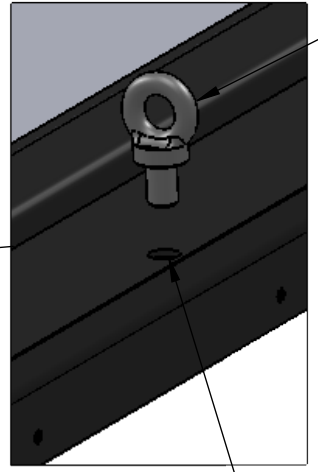

DETAIL C
 SCALE 1 : 3

REMOVABLE M12 EYEBOLT TO AID LIFTING OPERATION 4 PLACES.
 NOTE: EYE BOLT TO BE SCREWED TIGHT AGAINST FLANGE BEFORE COMMENCING LIFTING OPERATIONS

REMOVE EYEBOLT AFTER INSTALLATION & SEAL HOLE USING SILICONE SEALANT & M12x20 BUTTON HEAD SCREW 4 PLACES

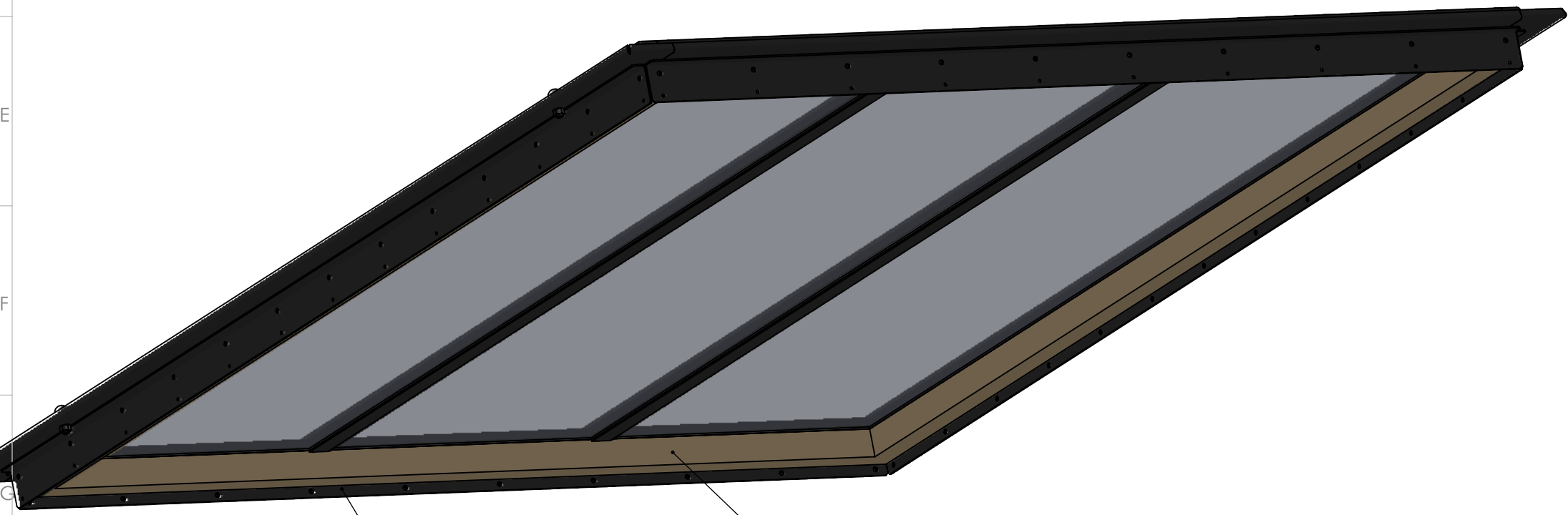

EUROPEAN OAK INTERIOR LINER

FIXING ANGLES TO ALL SIDES OF ROOFLIGHT COMPLETE WITH CSK SCREW FIXING HOLES



THE INFORMATION CONTAINED IN THIS DRAWING IS THE SOLE PROPERTY OF METAL & GLASS LTD. ANY REPRODUCTION IN PART OR AS A WHOLE WITHOUT WRITTEN PERMISSION IS STRICTLY PROHIBITED
 SHEET: 3 OF 3 - A3
 DATE: 07/05/21 UNITS: mm; kg

DRAWN: S.C
 SCALE: 1:10
 WEIGHT: 226

TITLE: BESPOKE FIXED CONSERVATION ROOFLIGHT GA
 REF: STELLA BESPOKE CONSERVATION ROOFLIGH

MATERIAL: 316 ST STEEL
 SEALS/SEALANT COLOUR: BLACK/BLACK
 FINISH: SWEEP BLAST & POWDER COAT PZ790 SYSTEM RAL7001 SILVER MATT FINISH

PART TYPE: MANUFACTURED
 PART REF:
 DRG. No.