

GENERAL INFORMATION
 3RD ANGLE PROJECTION
 DO NOT SCALE - IF IN DOUBT, ASK
 REMOVE ALL SHARP EDGES AND BURRS

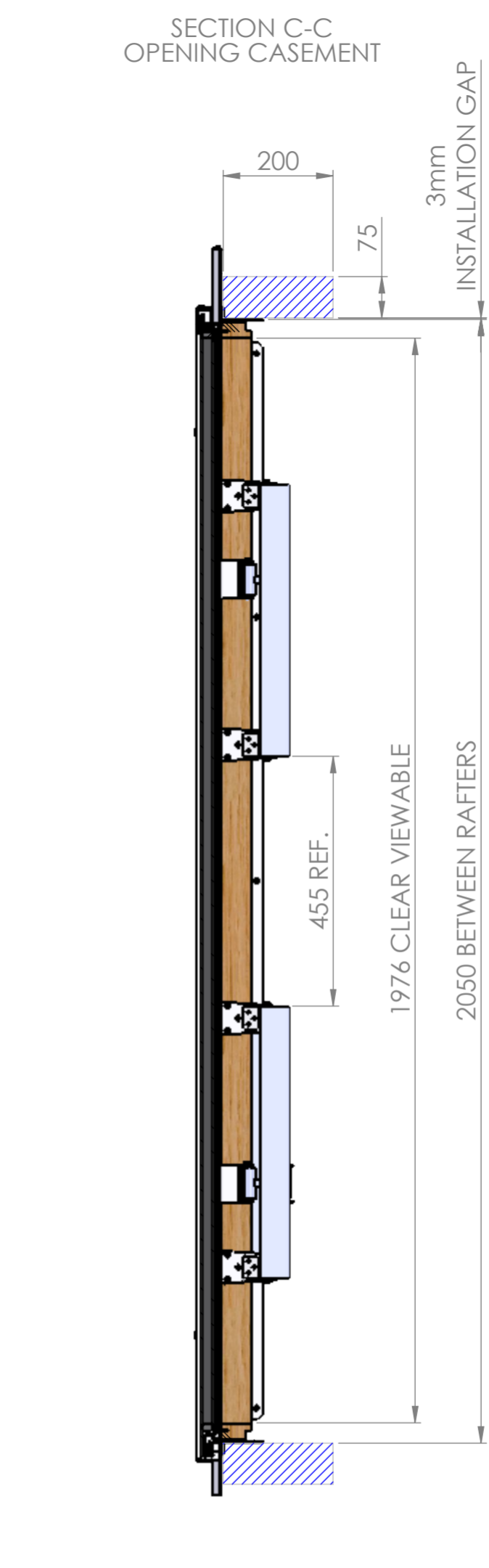
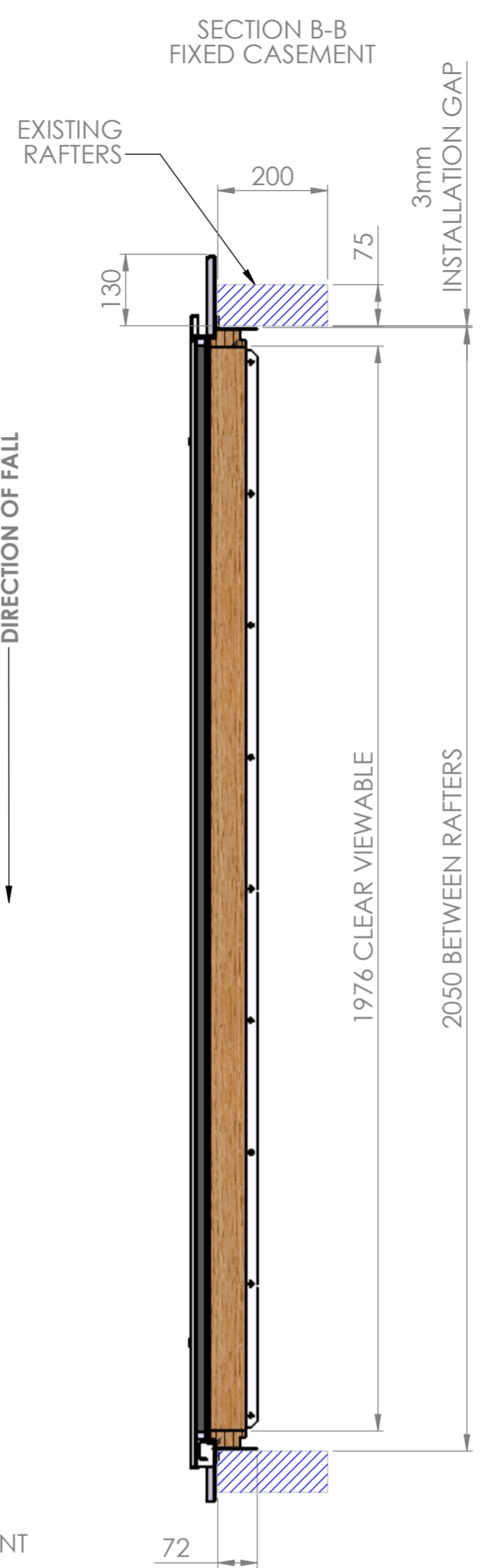
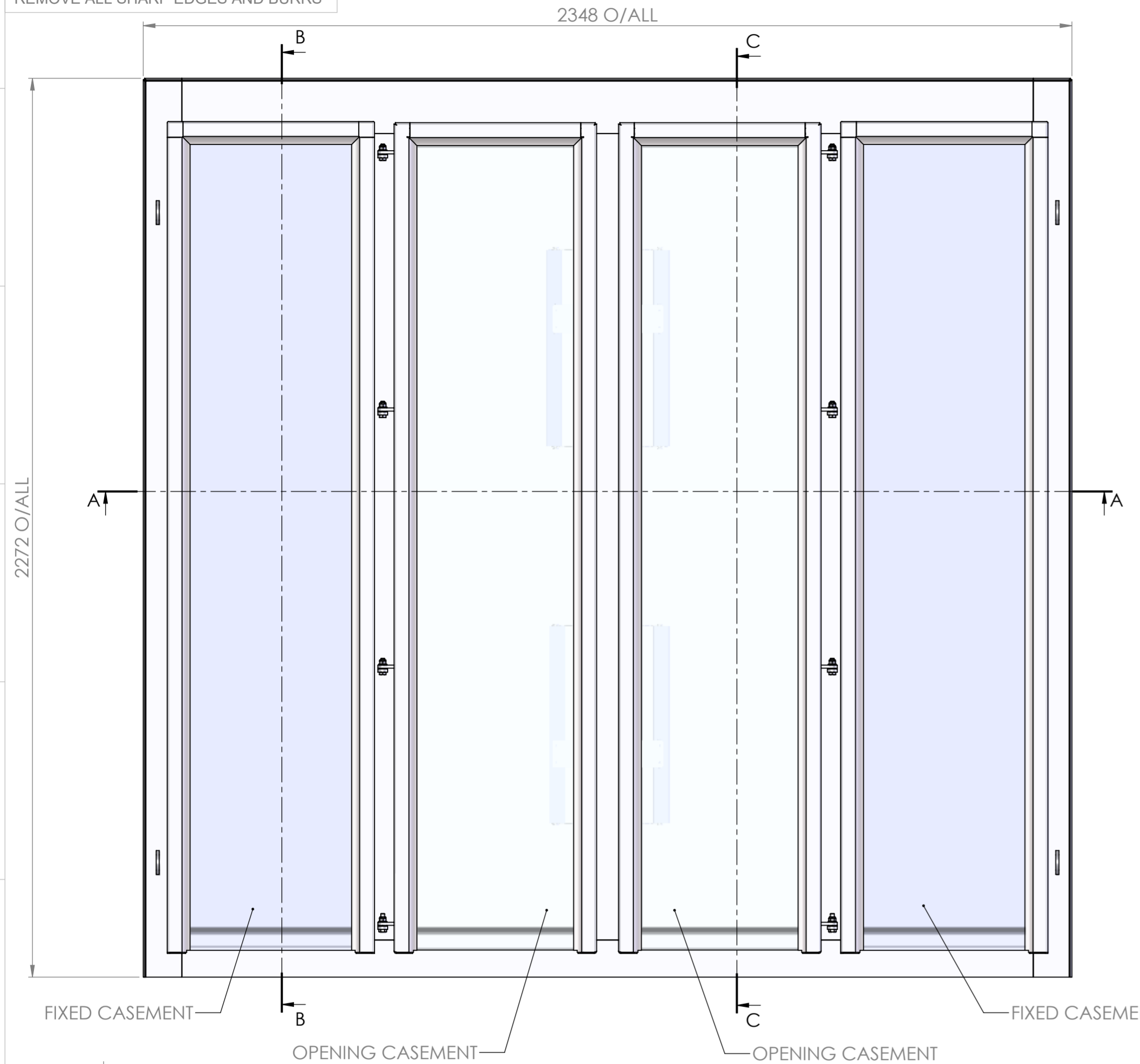

TOLERANCES UNLESS OTHERWISE SPECIFIED	
LINEAR - 0 DECIMAL PLACES	±1.0mm
LINEAR - 1 DECIMAL PLACES	±0.50mm
LINEAR - 2 DECIMAL PLACES	±0.15mm
ANGULAR	±1.0°
SURFACE FINISH - GENERAL	3.2 µm
SURFACE FINISH - MACHINED	1.6 µm
SURFACE FINISH - GROUND	0.4 µm
SURFACE FINISH - POLISHED	0.2 µm
SCREW THREAD - INTERNAL	6H
SCREW THREAD - EXTERNAL	6g

NOTE:
 INSTALLER TO PROVIDE ADEQUATE FITTING ALLOWANCE TO ALL SIDES OF ROOF OPENING TO ENSURE EASE OF INSTALLATION

ACTUATORS TO TO BE SUPPLIED AND FITTED TO ROOFLIGHT. ELECTRICAL CONNECTION AND INTEGRATION CLIENTS SYSTEM BY OTHERS

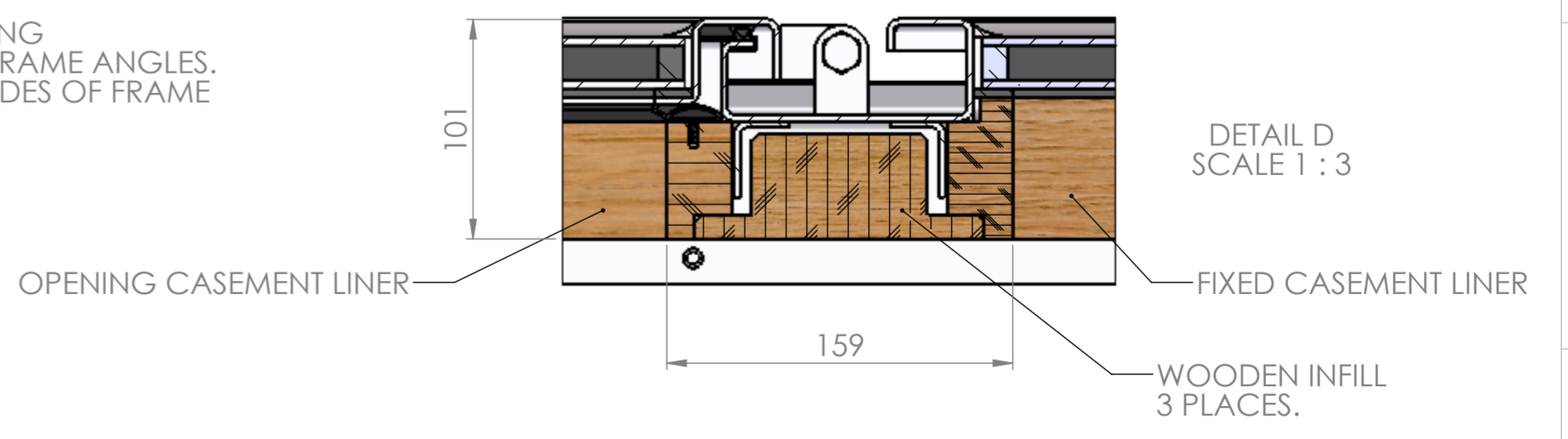
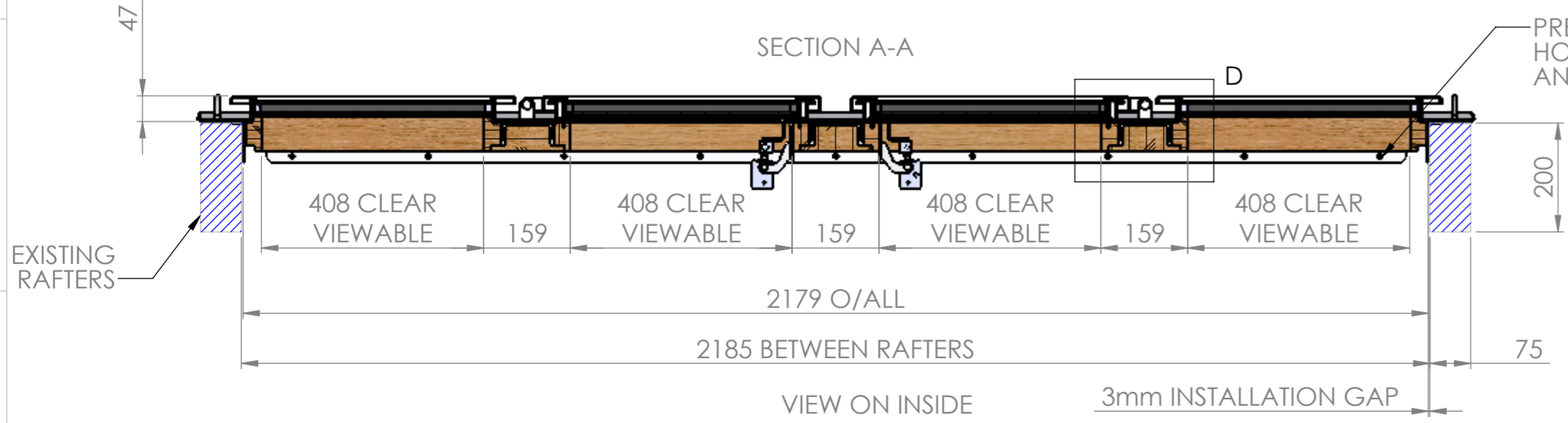

THE INFORMATION CONTAINED IN THIS DRAWING IS THE SOLE PROPERTY OF METAL & GLASS LTD. ANY REPRODUCTION IN PART OR AS A WHOLE WITHOUT WRITTEN PERMISSION IS STRICTLY PROHIBITED

SHEET: 1 OF 2 - A2
 DATE: 11/06/20

DRAWN: S.C
 SCALE: 1:10
 WEIGHT: 254
 UNITS: mm; kg

TITLE: BESPOKE OPENING ROOFLIGHT GA
 REF: 468

MATERIAL: 316 ST STEEL
 SEALS/SEALANT COLOUR: BLACK/BLACK
 FINISH: SWEEP BLAST & POWDER COAT PZ790 SYSTEM MNA05F BLACK

PART TYPE: MANUFACTURED
 PART REF: MGL0338A
 DRG. No. MGL0338A ISSUE: 2

GENERAL INFORMATION
 3RD ANGLE PROJECTION
 DO NOT SCALE - IF IN DOUBT, ASK
 REMOVE ALL SHARP EDGES AND BURRS

NOTE:
 4 OFF 24v DC. CHAIN DRIVEN
 ACTUATORS FITTED ARE HANDED.
 2 OFF EACH HAND

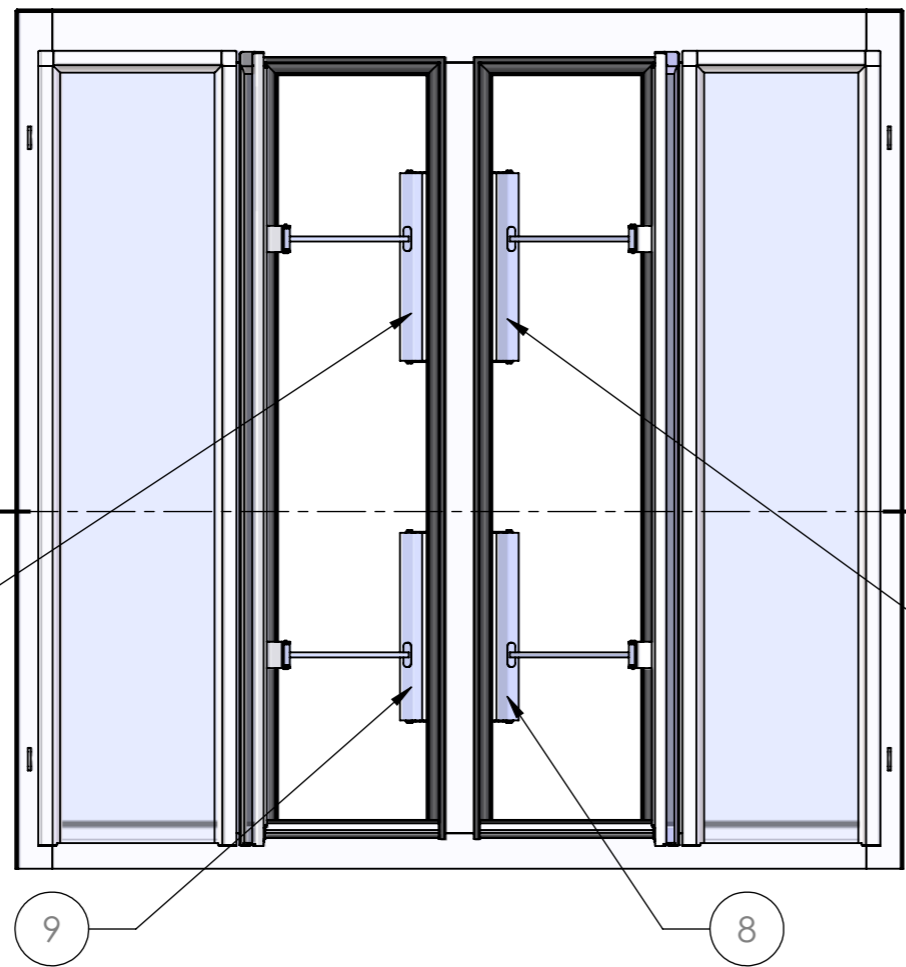

BOM Table			
ITEM NO.	PART NUMBER	DESCRIPTION	QTY.
1	MGL0339A	BESPOKE OPENING OUTER FRAME GA	1
2	MGL0340A	CASEMENT GA - L/H	1
3	MGL0341P	DOUBLE GLAZED UNIT - FIXED SHUT	2
4	MGL0083P	M10 HINGE WASHER	16
5	NUT273	M10 'P' TYPE NYLOC NUT - A2 ST STEEL	8
6	MGL0360A	CASEMENT GA - R/H	1
7	MGL0365P	KA34/54 ACTUATOR MOUNTING BRACKET	8
8	KA 34_54-500 STROKE, 24v DC, D+H CHAIN DRIVE		2
9	KA 34_54-500 STROKE, 24v DC, D+H CHAIN DRIVE - OPP HAND		2

TOLERANCES UNLESS OTHERWISE SPECIFIED	
LINEAR - 0 DECIMAL PLACES	±1.0mm
LINEAR - 1 DECIMAL PLACES	±0.50mm
LINEAR - 2 DECIMAL PLACES	±0.15mm
ANGULAR	
	±1.0°
SURFACE FINISH - GENERAL	
SURFACE FINISH - MACHINED	3.2 µm
SURFACE FINISH - GROUND	1.6 µm
SURFACE FINISH - POLISHED	0.4 µm
SCREW THREAD - INTERNAL	
SCREW THREAD - EXTERNAL	6H 6g

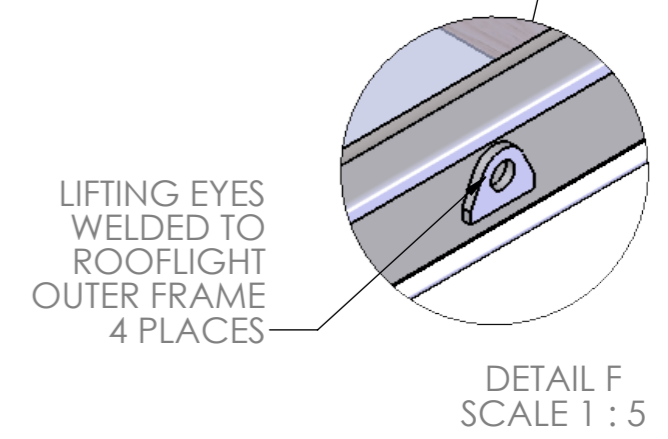
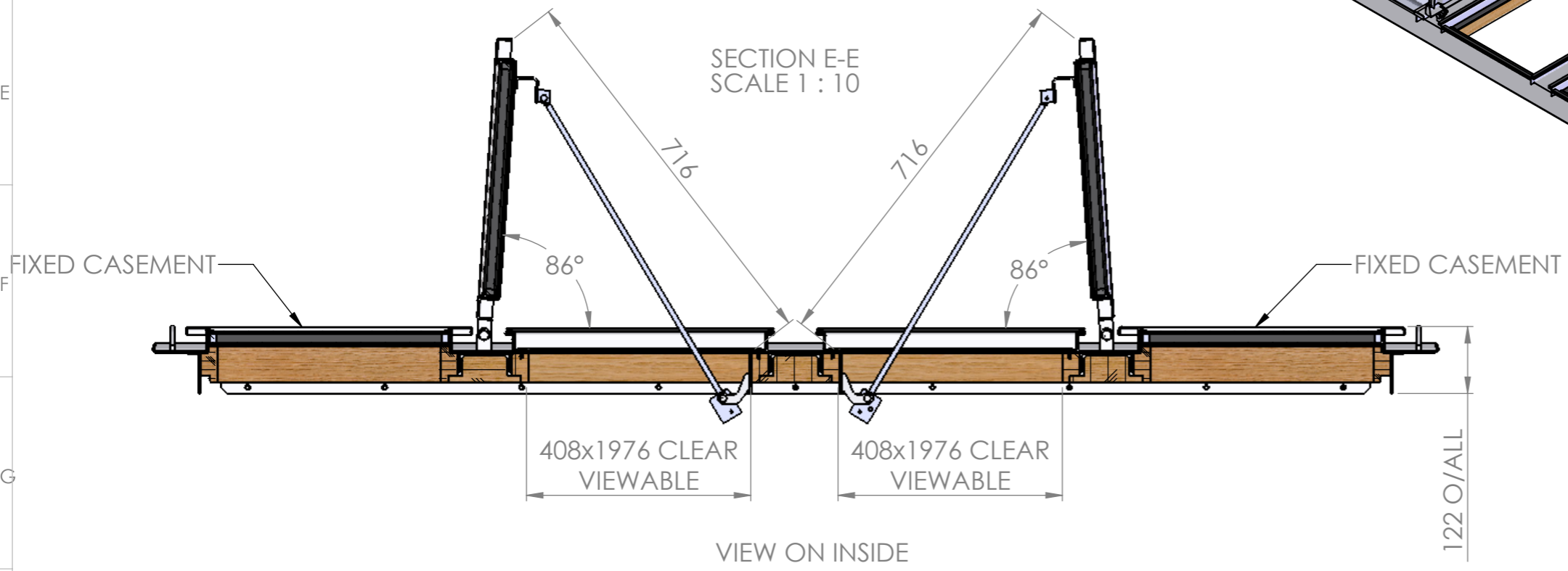
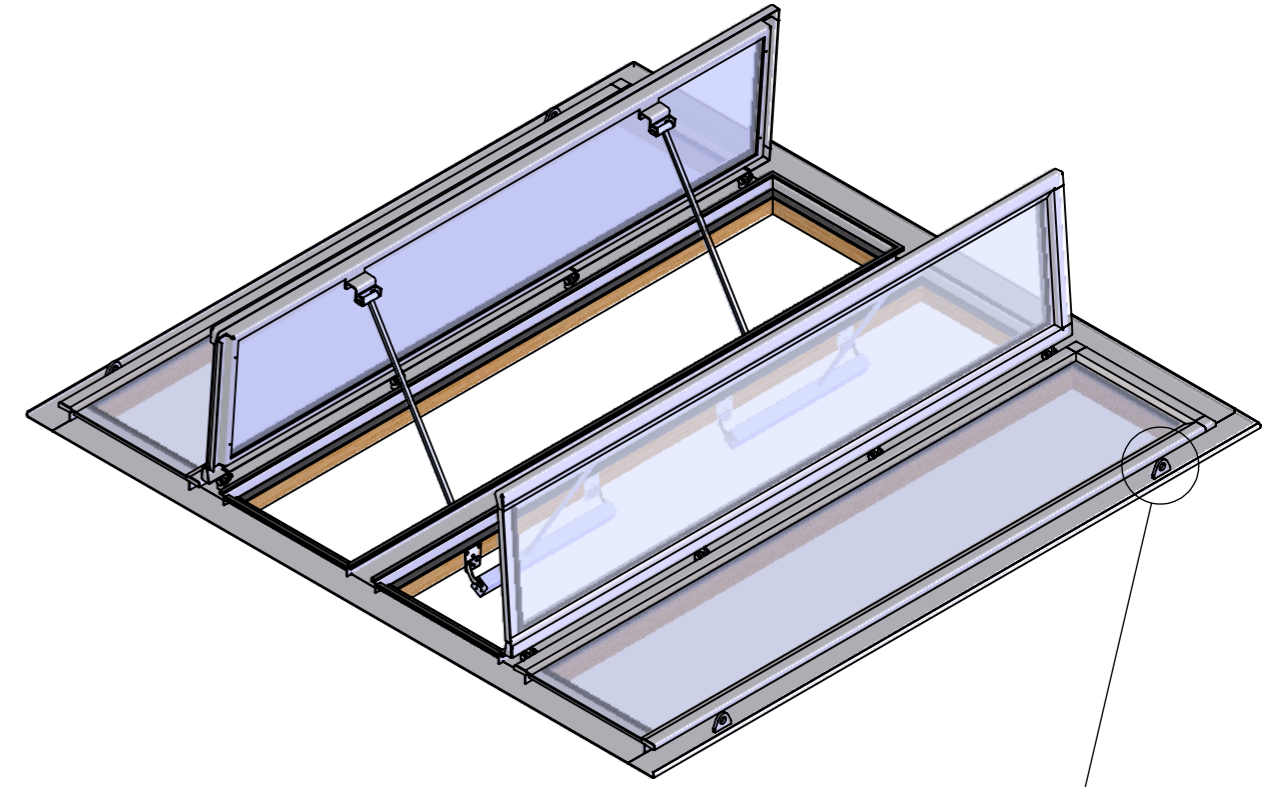

	THE INFORMATION CONTAINED IN THIS DRAWING IS THE SOLE PROPERTY OF METAL & GLASS LTD. ANY REPRODUCTION IN PART OR AS A WHOLE WITHOUT WRITTEN PERMISSION IS STRICTLY PROHIBITED.	DRAWN: S.C SCALE: 1:20 WEIGHT: 254	TITLE: BESPOKE OPENING ROOFLIGHT GA REF: 468	MATERIAL: 316 ST STEEL SEALS/SEALANT COLOUR: BLACK/BLACK FINISH: SWEEP BLAST & POWDER COAT PZ790 SYSTEM MNA05F BLACK	PART TYPE: MANUFACTURED PART REF: MGL0338A
	SHEET: 2 OF 2 - A3 DATE: 11/06/20 UNITS: mm; kg	DRG. No. MGL0338A ISSUE: 2			